

DL650 V-STROM CRASH BARS

INSTALLATION INSTRUCTIONS

Dear Rider,
Thank you for choosing Altrider! Whether a seasoned world adventurer or a first time ADV-Newbie, we welcome you to the Altrider experience. You can install your new product with the utmost confidence. Altrider designs, tests, and manufactures all of its products here in the United States. We are proud to do what we do and honored to present to you the product of our labors.

Enjoy it, show it off, and most of all, RIDE IT!

Venture On,
Jeremy LeBreton



Suzuki DL650 VStrom Crash Bars

Package Contents:
- Right and Left crash bars
- Hardware kit

Altrider LLC

Global

mailing: 4000 Aurora Ave N Ste 100
Seattle, WA 98103 USA
phone: 206-922-3618
email: info@altrider.com
web: www.altrider.com

Europe

mailing: Oude Middenweg 231-M
2491 AG DEN HAAG
Netherlands
email: info@altrider.eu
web: www.altrider.eu

Rev3





At a certain point in this installation you will be removing the side stand mount bolt. You'll either need to put your V-Strom on a center stand, or have a buddy hold the bike upright for you during those steps.

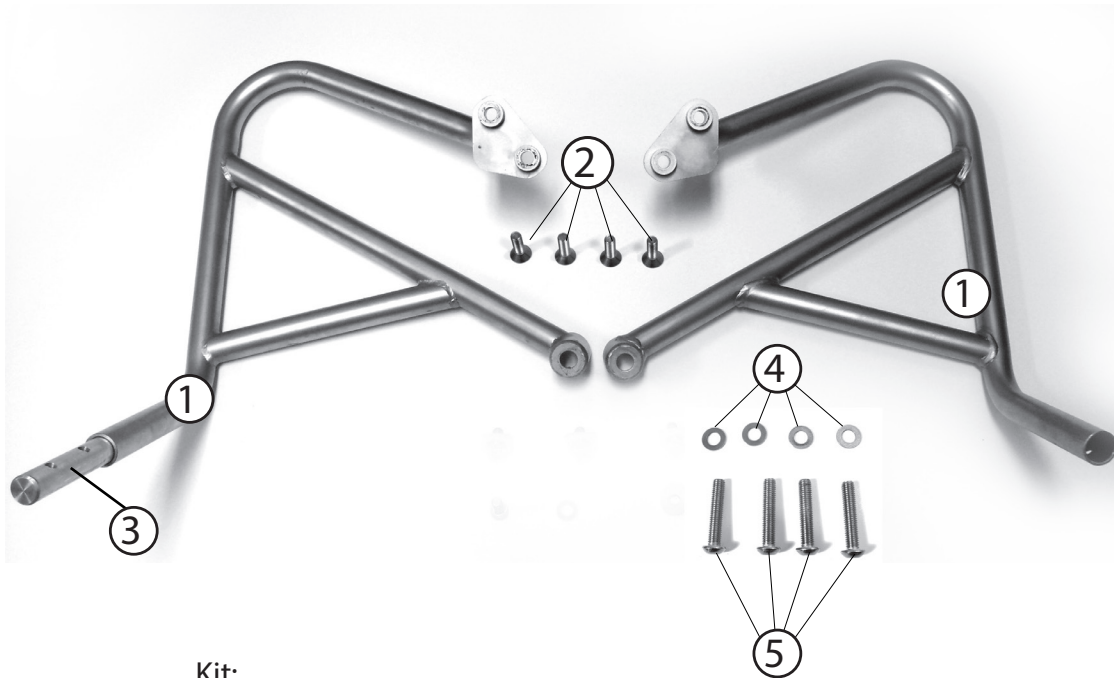

Kit:

- ① Crash Bars (L) and (R)
- ② (4) M6 x 20 stainless flathead fasteners
- ③ (1) connector (pre installed)
- ④ (4) M8 washers
- ⑤ (4) M8 x 40 stainless button head fasteners



Recommended tools:

- ① 1/2" ratchet
- ② 17mm socket
- ③ 1/4" driver
- ④ 1/4" ratchet
- ⑤ additional 17mm socket with extension
- ⑥ 4, 5 and 6mm allen
- ⑦ Torque wrench
- ⑧ (1) .5ml Loctite 271





- ① (a) Using a 4mm allen, remove the fastener on both sides of the bike. (b) After the fastener is removed it's held on only by rubber grommets, remove the plastic covers.

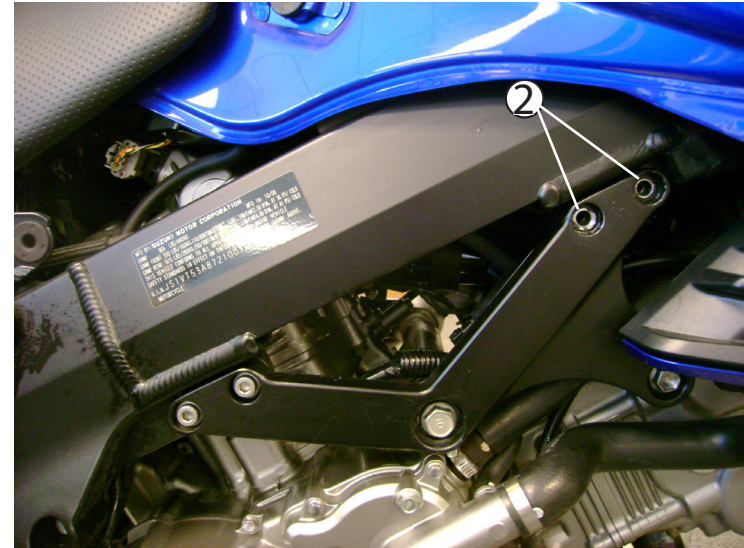

- ② Using a 6mm allen, remove the two top casting bolts on the right side where indicated.



- ③ Now set a 17mm socket in place on the motor mount nut. You will turn this side while holding the right side.

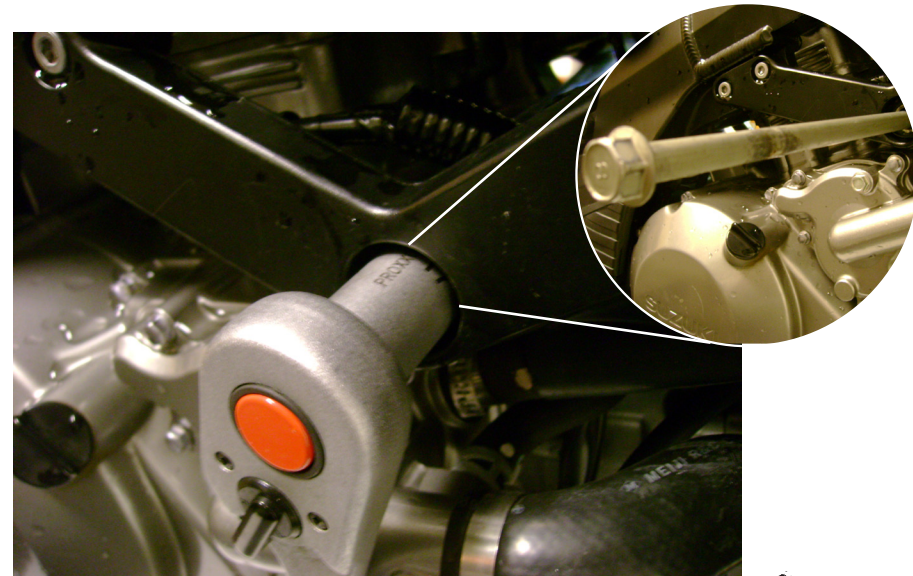

- ④ Remove the through-bolt as indicated above.



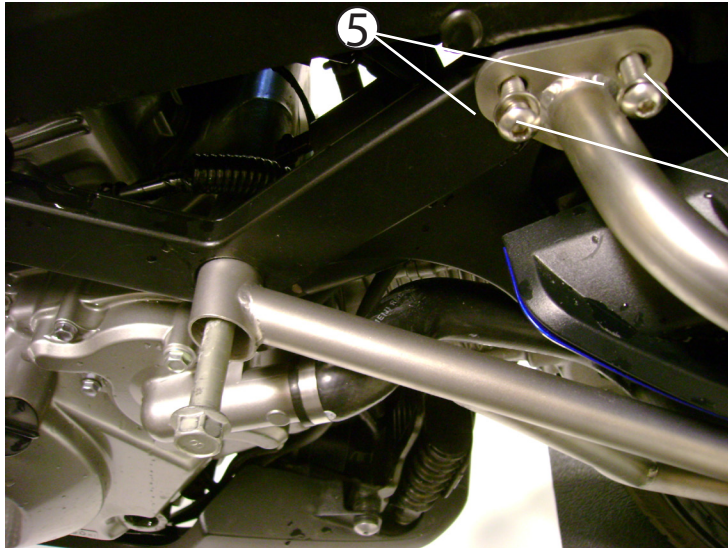

- ⑤ Put on the right side crash bar. Using a 5mm allen, insert the two M8 button head screws (with M8 washers) into the top mount flange, and slide the through-bolt back in place. Torque the M8s to 20Nm.

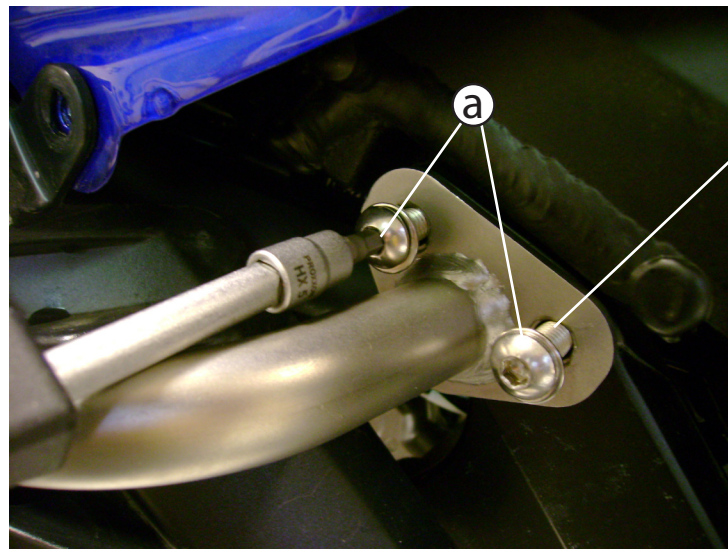

Loctite these 2 fasteners! One drop of Loctite on the last couple of threads.

- ⑦ (a) Using a 5mm allen, insert the two M8 button head screws (with M8 washers) into the top mount flange. Torque the M8s to 20Nm (b) Replace the through-bolt nut and tighten until the locking nut engages the bolt.

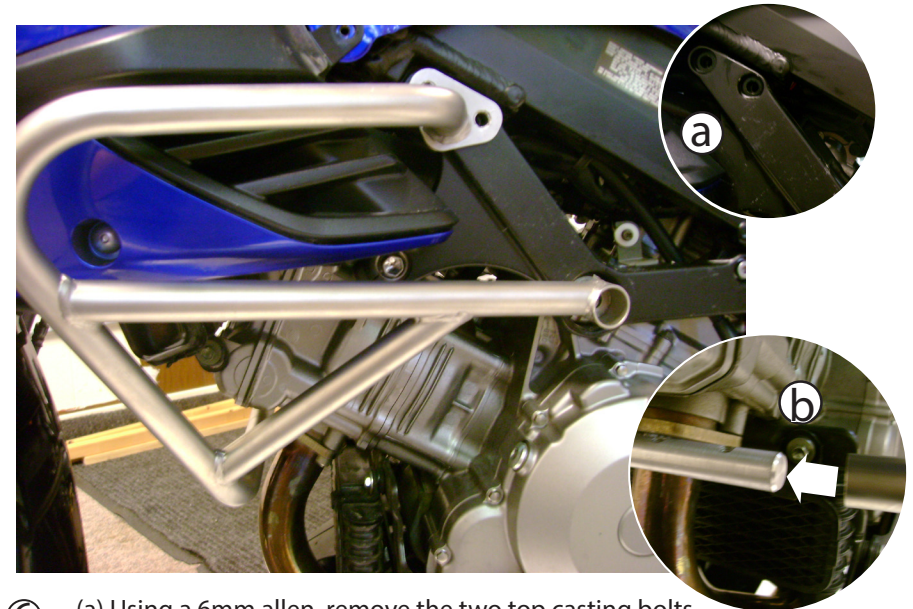

- ⑥ (a) Using a 6mm allen, remove the two top casting bolts. (b) Put the left side crash bar on, be sure that the front tube slides over the connector as you put it in place.



- ⑧ Using a 4mm allen, insert the flat head M6s into the four holes on the front underside of the assembly.



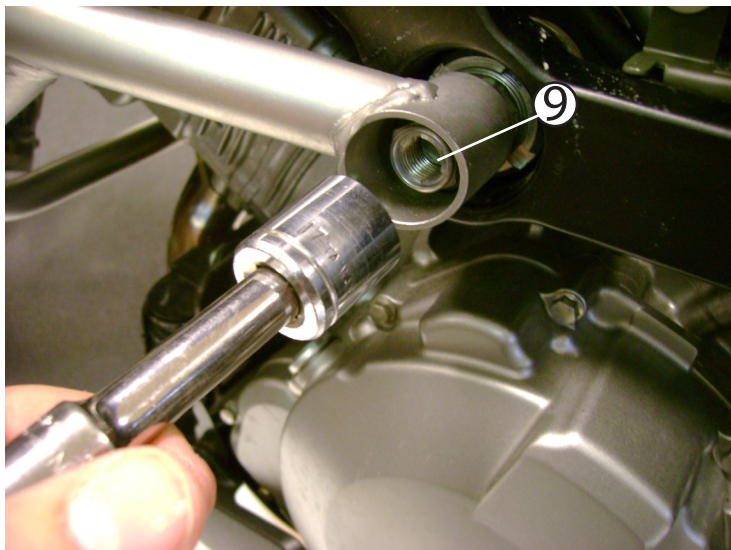

- ⑨ Torque the through-bolt nut down to 75 Nm.

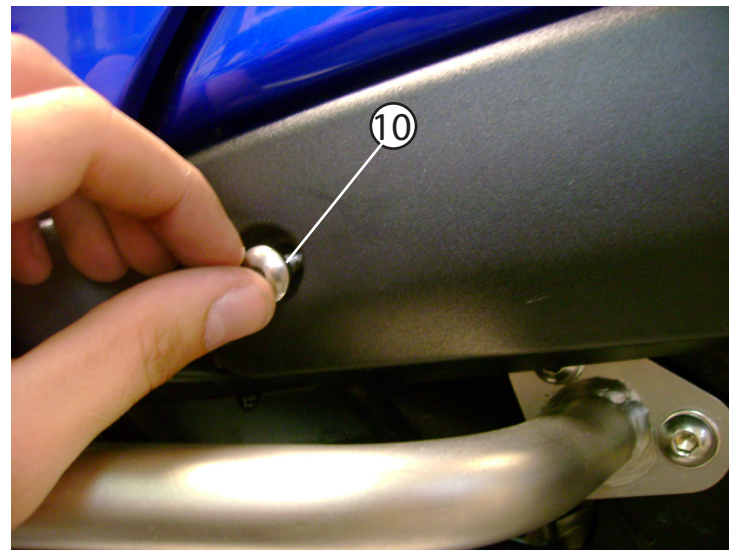

- ⑩ Replace the plastic cover pieces on both sides and reinsert the OEM fasteners. Do not over-tighten!



After 100 miles of riding with your new equipment installed, check all bolts to ensure they are still tightened properly.



CONGRATULATIONS!

You've completed your installation. If at any point you have questions about your installation or have any feed back for us, we'd love to hear it. A downloadable version of these instructions can be found at our web site. www.AltRider.com

Global Office:

email: info@AltRider.com
phone: +1 206-922-3618
address: 4000 Aurora Ave N
Ste 100
Seattle, WA 98103

Europe Office:

email: info@AltRider.eu
address: Oude Middenweg 231-M
2491 AG DEN HAAG
Netherlands

TERMS OF USE, WARRANTY AND LIABILITY WAIVER

AltRider LLC, a Washington company, having its principal place of business in Seattle, WA ("AltRider") offers its motorcycle accessories (the "Product") with the terms, conditions and notices as follows:

Terms of Use

This Product is offered to you conditioned upon your acceptance without modification of the terms, conditions, and notices contained herein. Installation and/or use of this product implies acceptance of all such terms, conditions, and notices. If you do not agree to these terms, do not buy the Product. If you have already bought the Product and do not agree to these terms, return this Product promptly including the packaging and all written materials, to AltRider.

Limitation of Liability and Warranty Disclaimer

You may return your merchandise for a full refund or exchange, less any original or return shipping fees under these conditions:

1. Only if the merchandise is in 100% factory condition. Original manufacturer's packaging and same condition as sold – original boxes, packaging material, instructions, documentation, parts, and attached tags.
2. Only unused, unscratched, uninstalled, undamaged merchandise will be accepted. Do not install equipment until you are sure you want to keep it. Package items carefully in protective materials before returning them. Never ship an item in its original manufacturers packaging – it will arrive damaged. Please use a postal box or other adequate packaging to ensure your return or exchange is not damaged on the way back to AltRider.com.

To read more about our exchanges and returns policy, on the web, navigate to www.alt rider.com/index.php/symfony/exchangesAndReturns

Excepting the warranties stated in the preceding paragraph, AltRider hereby disclaims all other warranties and conditions with regard to the Product including all implied warranties and conditions of merchantability and fitness for a particular purpose. There are no warranties which extend beyond the description on the face hereof. AltRider does not warrant against damages or defects arising out of use or installation of the Product. Installation instructions are provided for your convenience. AltRider is not responsible for any damages arising out of the installation, improper or otherwise, of the Product. No warranty of any kind, expressed or implied, is made regarding the safety of this Product.

To the extent allowed by law, AltRider shall not be held liable for any direct, indirect, punitive, incidental, special or consequential damages arising out of, or connected with, the use or misuse of this Product. Buyer assumes all risks and liability arising from use of this Product.

Entire Agreement

This document states the entire obligation of AltRider with respect to the Product. If any part of this agreement is determined to be void, invalid, unenforceable or illegal, including, but not limited to the warranty disclaimers and liability limitations set forth above, then the remainder of the agreement shall remain in full force and effect.

Applicable Law

This agreement is governed by the laws of Washington, USA. You hereby consent to the exclusive jurisdiction and venue of the courts of Washington, USA, in all disputes arising out of or relating to the use of this product.

